

# TAKISAWA®

## Operator's Manual

### TSL 550D, 800D, 1000D

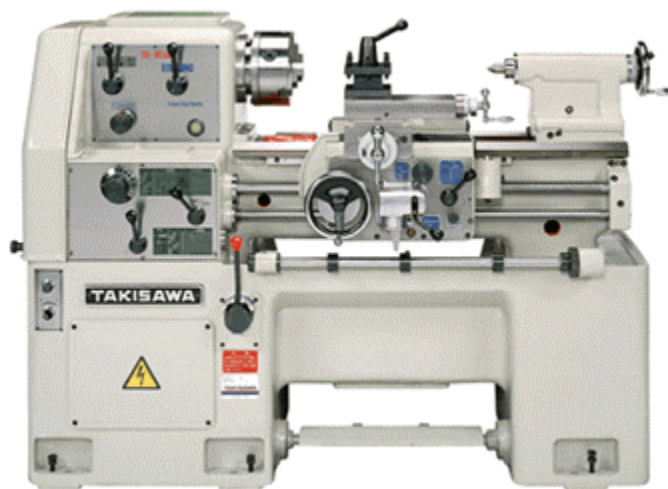

CONTENTS

	Page
Specifications.....	1
Dimension drawing.....	2
Foundation layout.....	3
Standard equipment & Extra equipment.....	4
Installation	
Foundation.....	5
Lifting.....	5
Leveling.....	6
Electric wiring.....	7
Lubrication	
Lubrication chart.....	8
Lubricating point.....	9
Lubrication to headstock.....	10
Lubrication to gear box.....	10
Lubrication to carriage, apron and bedways.....	10
Construction.....	12, 13
Operation	
Preparation for operation.....	14
Starting and stopping of headstock spindle.....	15
Changing spindle speeds.....	15
Drive unit.....	16
Power feed of carriage.....	17
Manual feed of carriage.....	17
Operation of thread cutting.....	18
Automatic longitudinal feed stop bar.....	18
Tailstock.....	19
Mounting of chuck and face plate.....	19
Thread chasing dial.....	20
Adjustment	
Leveling of the bed slide ways.....	21
Adjustment of the headstock.....	21
Adjustment of the spindle bearing.....	22
Adjustment of the apron teeth clutch.....	22
Adjustment of the gib.....	23
Adjustment of the female screw of the cross slide....	23
Centering and adjustment of the tailstock.....	23
Adjustment of the brake.....	24
Adjustment of the microswitch.....	24
Adjustment of the square turret tool post.....	25
Trouble shooting chart.....	26, 27
Notes in general.....	28

Specifications		TSL-550D	TSL-800D	TSL-1000D
Swing over bed		360mm 14 1/8"	360mm 14 1/8"	360mm 14 1/8"
Height of center		180mm 7"	180mm 7"	180mm 7"
Swing over cross slide		210mm 8 1/4"	210mm 8 1/4"	210mm 8 1/4"
Swing over bed (from face plate to 100mm)		400mm 16"	400mm 16"	400mm 16"
Distance between center		550mm 20"	800mm 30"	1000mm 40"
Length of bed		1360mm 53"	1610mm 63"	1810mm 71"
Width of bed		275mm 10 13/16"	275mm 10 13/16"	275mm 10 13/16"
Floor to work center		980mm 38 1/2"	1055mm 980mm 41 1/2" 38 1/2"	1055mm 41 1/2"
Hole thru spindle		35mm 1 3/8"		
Center taper		MT NO. 3	MT NO. 3	MT NO. 3
Spindle taper		MT NO. 5	MT NO. 5	MT NO. 5
Spindle nose		ASA A1-5"	ASA A1-5"	ASA A1-5"
Tailstock spindle taper		MT NO. 3	MT NO. 3	MT NO. 3
Spindle speeds	Number	6	6	6
	Range	83-1800RPM	83-1800RPM	83-1800RPM
Taper roller bearing at front		#32214	#32214	#32214
Taper roller bearing at rear		#30211	#30211	#30211
Feeds..... Longitudinal feeds	Number	36	36	36
	Range	M.	0.05-3.60 mm	
		Inch	0.0020"-0.1417"	
	Gross feeds	1/2 of long.	1/2 of long.	1/2 of long.
Inch threads	Number	31	31	31
	Range	2-56 tpi	2-56 tpi	2-56 tpi
Metric threads	Number	18	18	18
	Range	0.5-9mm	0.5-9mm	0.5-9mm
Motor		2.2kw 3hp 3.7kw 5hp	2.2kw 3hp 3.7kw 5hp	2.2kw 3hp 3.7kw 5hp
Overall length		1622mm 64"	1872mm 74"	2072mm 82"
Overall width		725mm 28 1/2 "	725mm 28 1/2 "	725mm 28 1/2 "
Weight (Approx.)		1000kgs	1100kgs	1200kgs

STANDARD EQUIPMENT

Driving plate ( 6" ).....1 set  
Change gear .....1 set  
Screw driver .....2 pieces  
Double ended wrench.....2 "  
T-socket wrench .....1 piece  
Hex wrench .....10pieces  
Sleeve MT No.5 x No.3.....1 piece  
Center MT No.3 .....2 pieces  
Foundation bolt .....1 set  
Tool box .....1 set  
7" 3-jaw universal chuck .....1 set  
Automatic longitudinal feed stop bar .....1 set

EXTRA EQUIPMENT

Coolant equipment  
Tracer unit  
Rear tool post  
4-jaw chuck  
Chip guard  
Live center  
Taper attachment  
Steady rest  
Follow rest  
Face plate

## INSTALLATION

### Foundation

Construct the foundation with foundation iron plates in standard accessories.

For TSL, insert two steel bars ( $30\phi \times 1m$ ) into the lifting hole, and raise the machine slightly to assure proper balance before continuing using 15mm dia. wire rope. Make sure the machine does not touch with the wire rope. The carriage may be moved to help balance the lathe for moving by crane. Do not jerk as damage could occur.

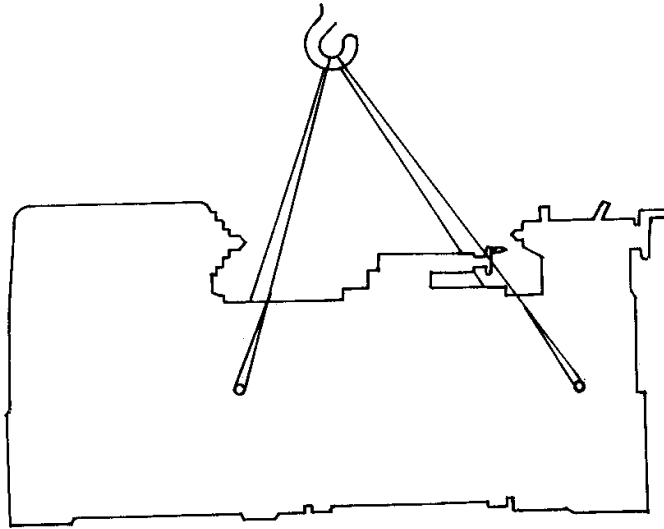

## Leveling

Your TAKISAWA lathe was aligned and accurately checked with lathe in perfect level. As the level of the machine exercise a great influence upon the accuracy and machine life, please take notice of the adjustment. Place steel plates on the foundation holes and set the lathe in position little by little. Insert the foundation bolts through the foundation holes and lock the washers and nuts properly. Then level the lathe with wedges roughly. Pour mortar into the foundation holes. After the mortar was solidified, remove the wedges and adjust the adjusting bolts. Straightness of bed slideways (longitudinal direction) should be 0.04mm per lmm. (See attached Accuracy Test Chart) In leveling, tighten the nuts for adjusting bolts and for foundation bolts. Please prevent from leaving the machine for long time in packing or improper condition.

## Electric wiring

Connect a source of electricity by checking the motor rotation. When checking the rotating direction after connecting, turn the switch (1) after placing the starting lever (10) to the stop position. Next, move the lever (10) to the left side, so the spindle begins to rotate. In this case, if the spindle rotates anti-clockwisely, the motor's rotation is forward.

ELECTRIC CIRCUIT DIAGRAM FOR SINGLE SPEED MOTOR

3φ 4 W

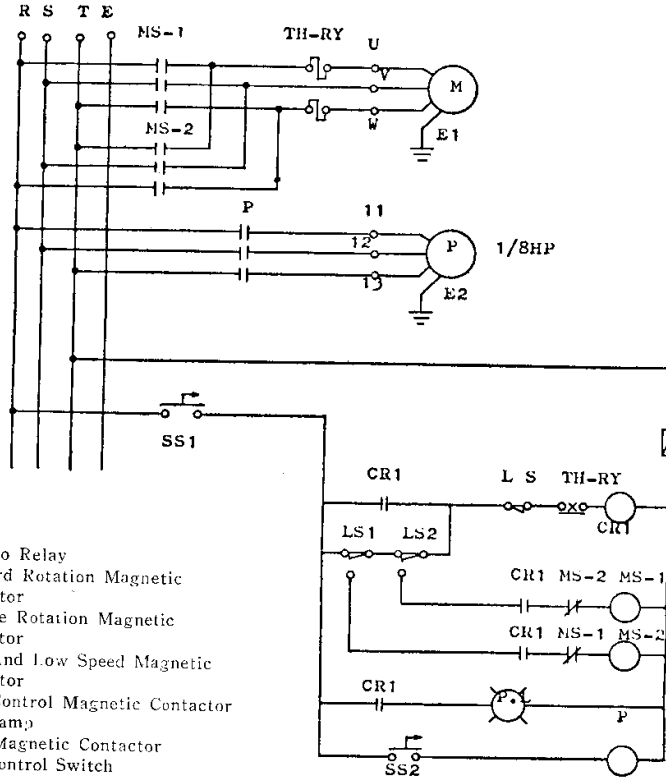

- TH-RY: Thermo Relay
- MS1 : Forward Rotation Magnetic Contactor
- MS2 : Reverse Rotation Magnetic Contactor
- H.L : High And Low Speed Magnetic Contactor
- CR1 : Main Control Magnetic Contactor
- P.L : Pilot Lamp
- P : Pump Magnetic Contactor
- SS1 : Main Control Switch
- SS2 : Pump Control Switch
- SS3 : High And Low Speed Control Switch
- L.S : Brake Limit Switch
- L.S1 : Start Lever Limit Switch
- L.S2 : Start Lever Limit Switch

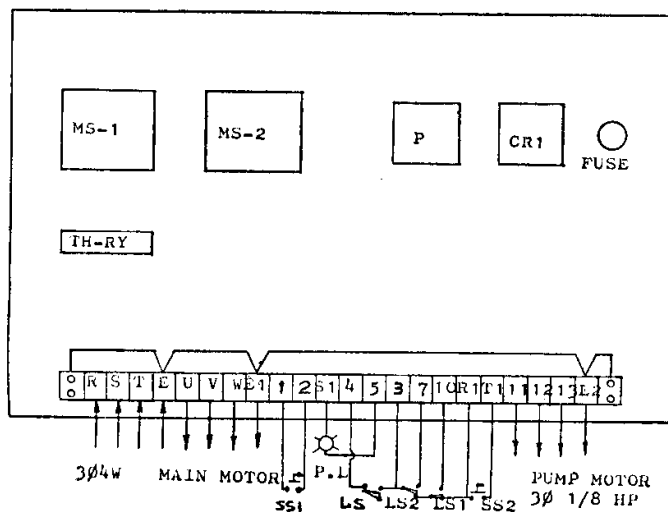
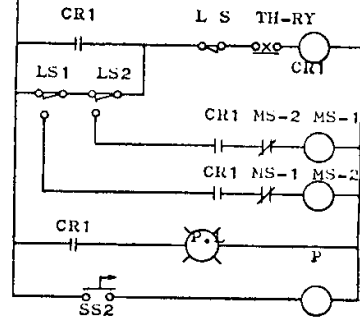

LUBRICATION

Lubrication chart ( See fig. 3 )			
Station	Amount	Recommended lubricant	Oil change interval & time of supply
⑩ Headstock	2.5	Mobil Velocite No.6 Shell Tellus No.13	3 months after installation and then every 6 months
⑩ Apron	0.5	Mobil Vacra NO.2 Shell Tonna 33	"
② Gear box	Properly	Mobil Velocite No.6 Shell Tellus No.13	Each day before starting lathe
⑭ Lead screw, Feed screw, Bracket	"	Mobil Vacra No. 2 Shell Tonna 33	"
⑫ Tailstock	"	"	"
⑤⑦ Female screw for cross slide	"	"	"
⑧⑨ Female screw for tool slide	"	"	"
⑮ Bed ways and carriage surface	"	"	"
⑥ Bearing for tool, post	"	"	"
Active shaft	"	"	"



LUBRICATING POINTS

Fig. 3

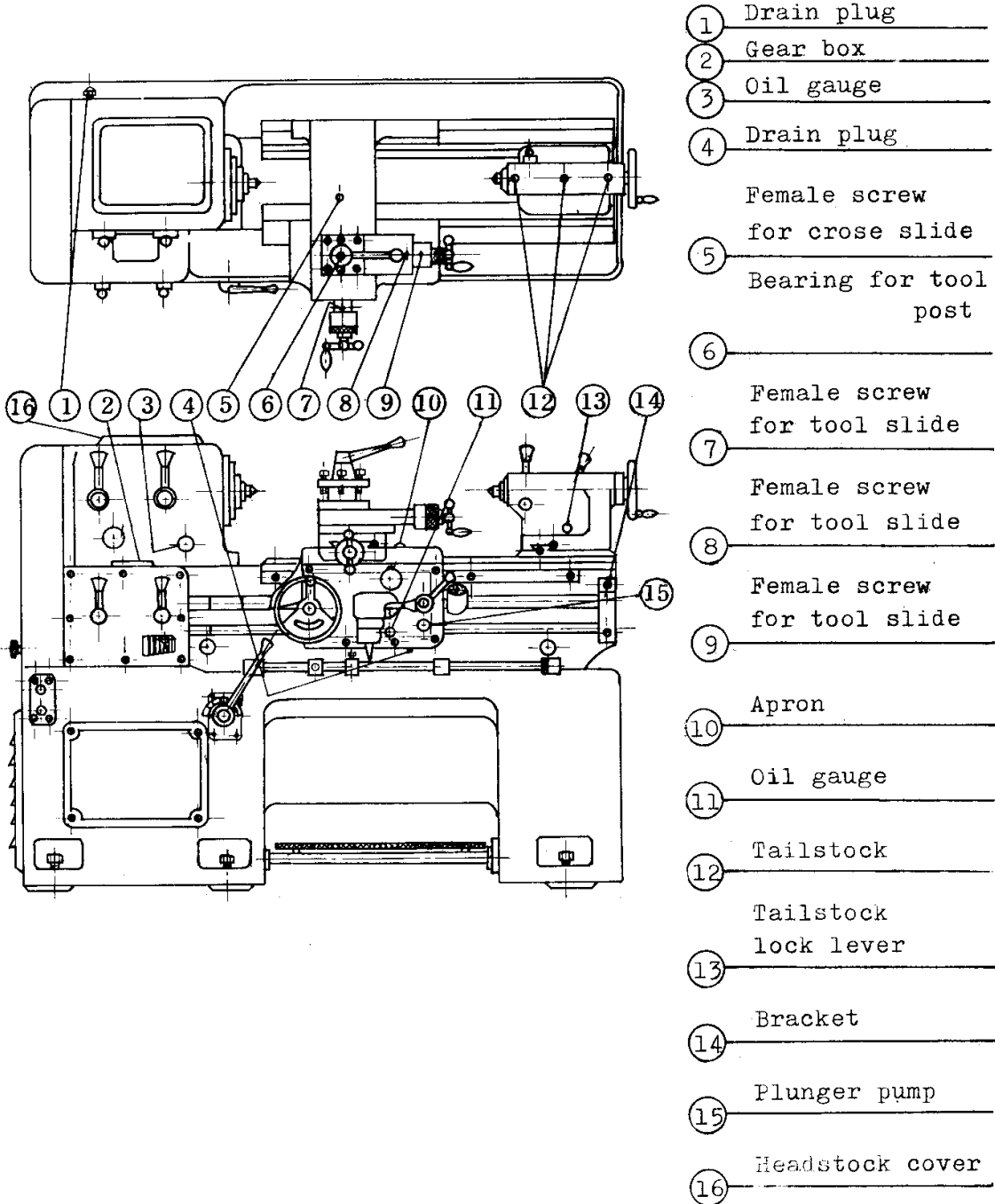

### Lubrication to headstock

Remove the head cover (16) and fill oil to level on oil sight gage (3). Lubrication to headstock is lubricated by oil distributors from oil reservoir and supply to all bearings and gears in the headstock. Oil change interval is about 3 months after installation and then every 6 months.

When replacing the lubricant, remove the oil drain plug (1) at the rear side of the headstock. Every oil refreshment, clean the pipe and oil tank.

### Lubrication to the gear box

Fill oil cup (2) on top side of the gear box. Oil in oil tray supplied to gears, bearings through oil distributor.

### Lubrication to carriage, apron and bedways

Fill oil reservoir weekly to level on oil sight gage (11). When lubricating the carriage and apron, push and pull until oil appears in tell -tale hole at right hand shear wiper, this oils carriage, bedways and cross slide. Please exchange oil in apron every 6 months.

When replacing the lubricant, remove the oil drain plug (4) at the bottom of the apron.

Fig.4

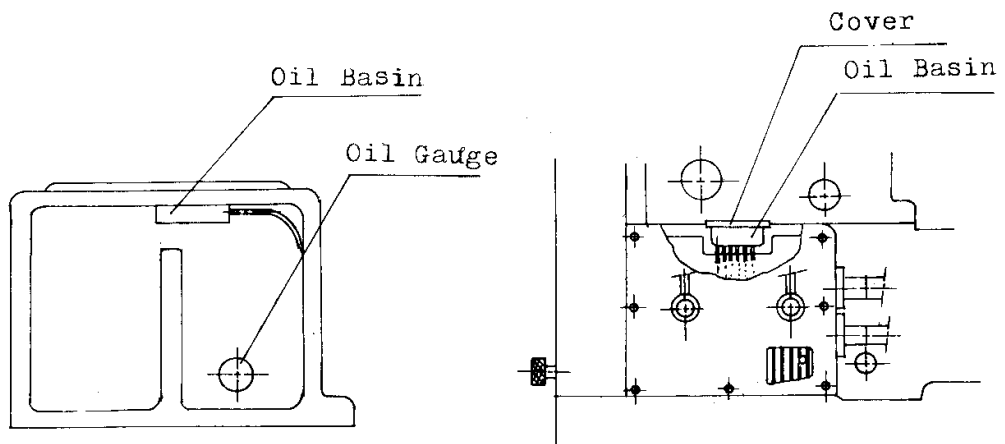
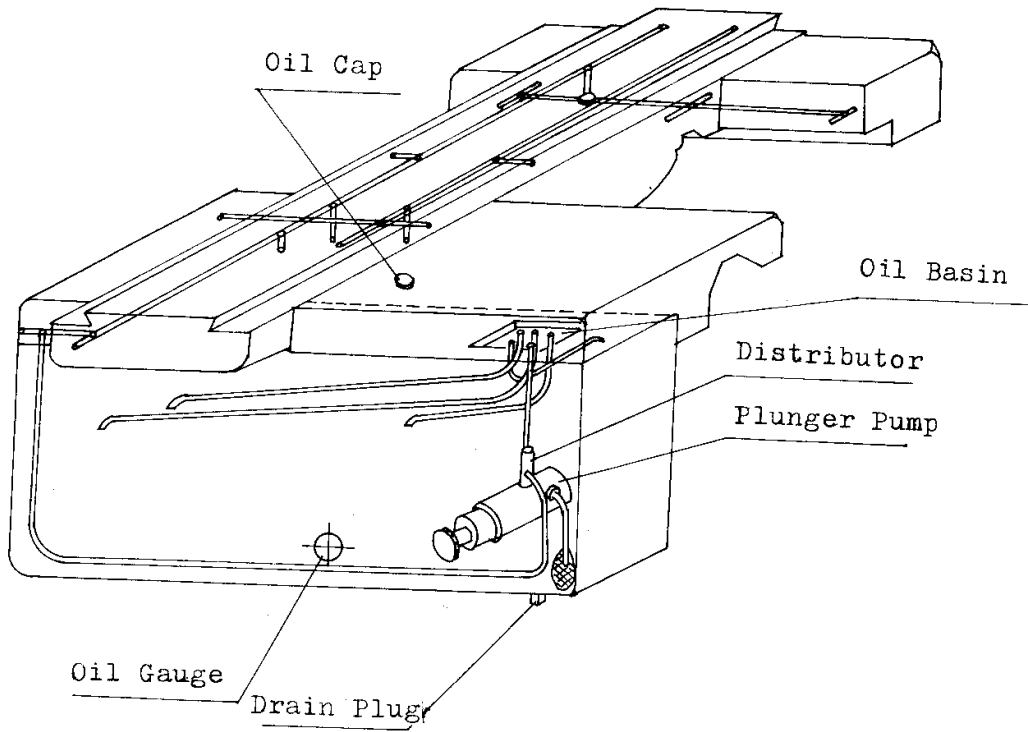

## CONSTRUCTION

### Headstock

Ribbed housing construction. Hardened and ground gears in headstock. Heat treated and ground spindle supported by two precision taper roller bearings. 35mm ( $1\frac{3}{8}$ " ) hole through spindle. ASA A-1-5" short taper spindle nose. Hardness of spindle is about 70 HS at nose, 65 HS bearing and taper parts. Safety device built in the spindle operation lever. 6 spindle speeds from 83 to 1800 rpm. Oil bath lubrication.

6 Spindle Speeds	83	155	270
	560	1030	1800

### Bed

Wide and fully ribbed with hardened and ground bedways.

### Carriage

Wide H-shaped cast saddle, in order to withstand heavy cutting. Plunger for one-shot lubrication of bed and saddle ways. The micrometer collar of cross feed handle provides 5mm of feed per revolution and 0.02 mm per graduation.

## Apron

Apron contains teeth clutch so that power feed operation is very easy. The feed change knob (13) and the half nut lever (12) are interlocked to prevent simultaneous engagement. Automatic longitudinal feed stop is mounted with standard equipment for TSL-D type.

## Gear box

Norton type (for TSL-D type)

Simple feed and thread selection by Norton type gear box.

31 inch threads from 2 to 56.

18 metric threads from 0.5 to 9.

36 power feed. The leadscrew is available to fit 6 tpi.

6 mm pitch and 4 mm pitch.

## Tailstock

Rigid and robust tailstock is clamped in any position firmly by the lever (22).

Heat treated and ground spindle is in position to the headstock in size.

# OPERATION

## Preparation for operation

Adjust the V-belt tension after opening the rear cover.  
 Before starting the machine, consult the section on  
 "Lubrication" for the proper lubrication points and the  
 fillers for the reservoirs.

Make sure the machine is properly lubricated before starting  
 in order to avoid damaging any bearing surfaces.

Spindle speed range	Cycle	Motor pulley	Length of V-belt
83-1800	60	78.6mm $\phi$ (3 3/32")	66" A-type
	50	94 mm $\phi$ (3 11/16")	67" A-type

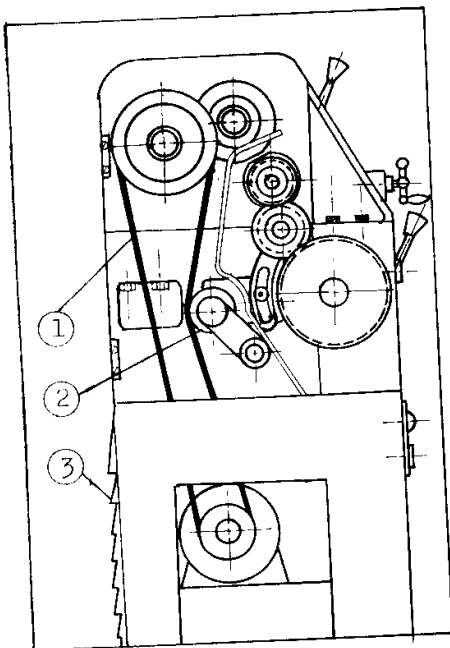

- ① V-belt (A-type, 3 pcs.)
- ② Tension pulley
- ③ Ventilator

## Starting and stopping headstock spindle

Please operate the machine along next order.

1. Make sure the position of the lever (10)
2. Turn the comand switch (1) to the right, pilot lamp (2) will light. This shows that the machine is ready for operation.
3. Turn the lever (10) to the left for forward rotation.  
Turn the lever (10) to the right for reverse rotation.
4. Step the brake pedal (9) and could stop spindle.
5. Place the lever (10) to "STOP" position.  
Pilot lamp (2) will light and the machine will be ready for operation again.

(See fig 5)

## Changing spindle speeds

The speeds are easily selected two levers (5) and (8) giving speeds of 83 to 1800 rpm. Spindle speeds should be changed only after the machine is stopped.

(Note: Don't operate the lever during running.)

Cutting speed and cutting time are as follows.

CUTTING SPEED TABLE

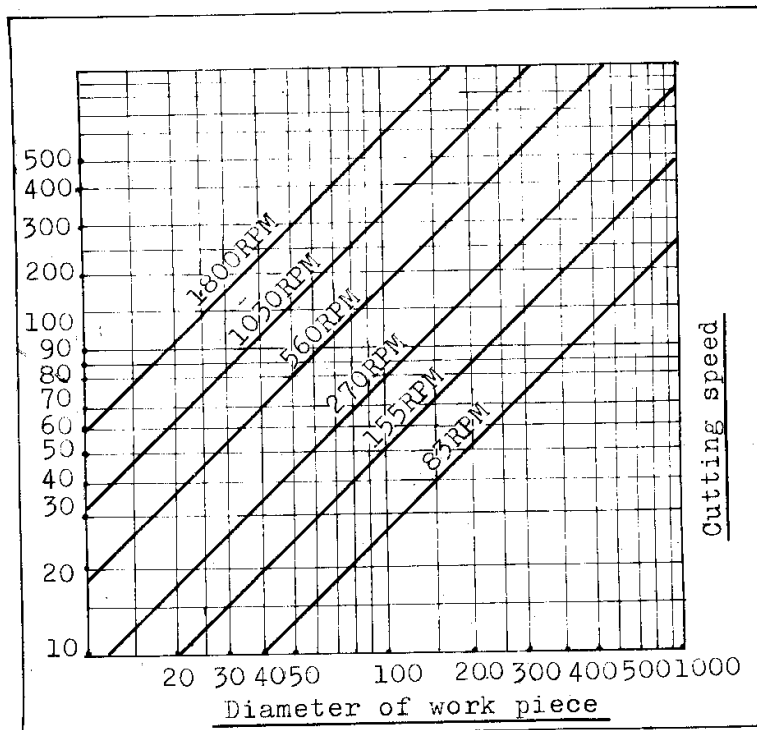

DRIVE UNIT

FIG. 5

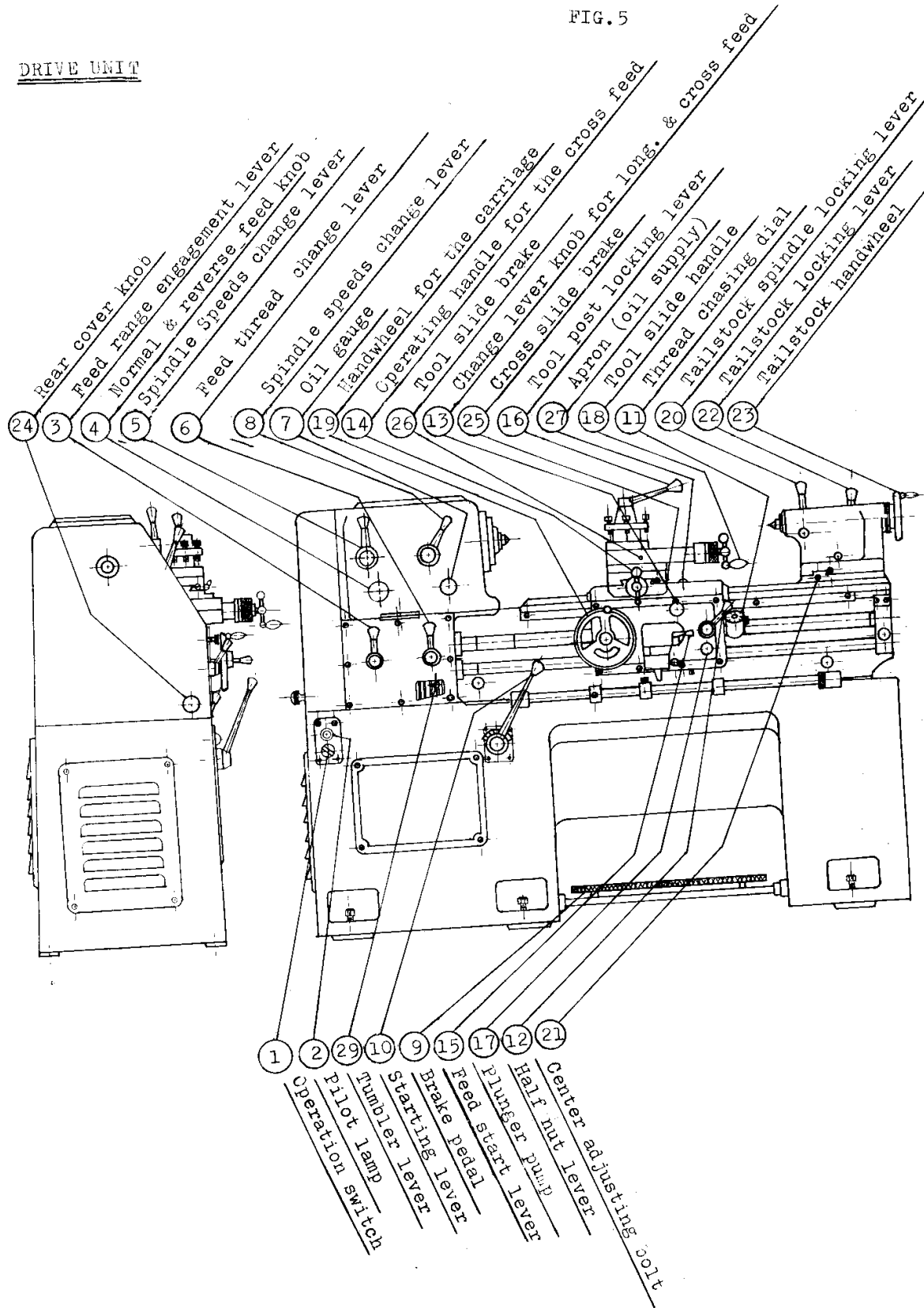



## Power feed of carriage

1. Open the rear cover (24) and assemble change gears according to the index plate.
2. Set the comand switch (1) .
3. Turn the forward and reverse knob (4) to the right (in case forward rotation) or the left (in case reverse rotation.)
4. Place the feed change lever (3), (29) on the desired position according to the plate.
5. Place the feed thread change lever (6) to the "FEED SIDE".
6. Operate the starting lever (10) .
7. Turn the change knob for longitudinal and cross feed (13) .
8. Pull up the feed on lever (15) .
9. Push down the feed on lever (15) .

## Manual feed of carriage

Longitudinal feed is done with the handwheel (19) for the carriage.  
Cross feed is with the cross feed operating handle (14) .  
Feed of tool slide is with the tool slide handle (18) .

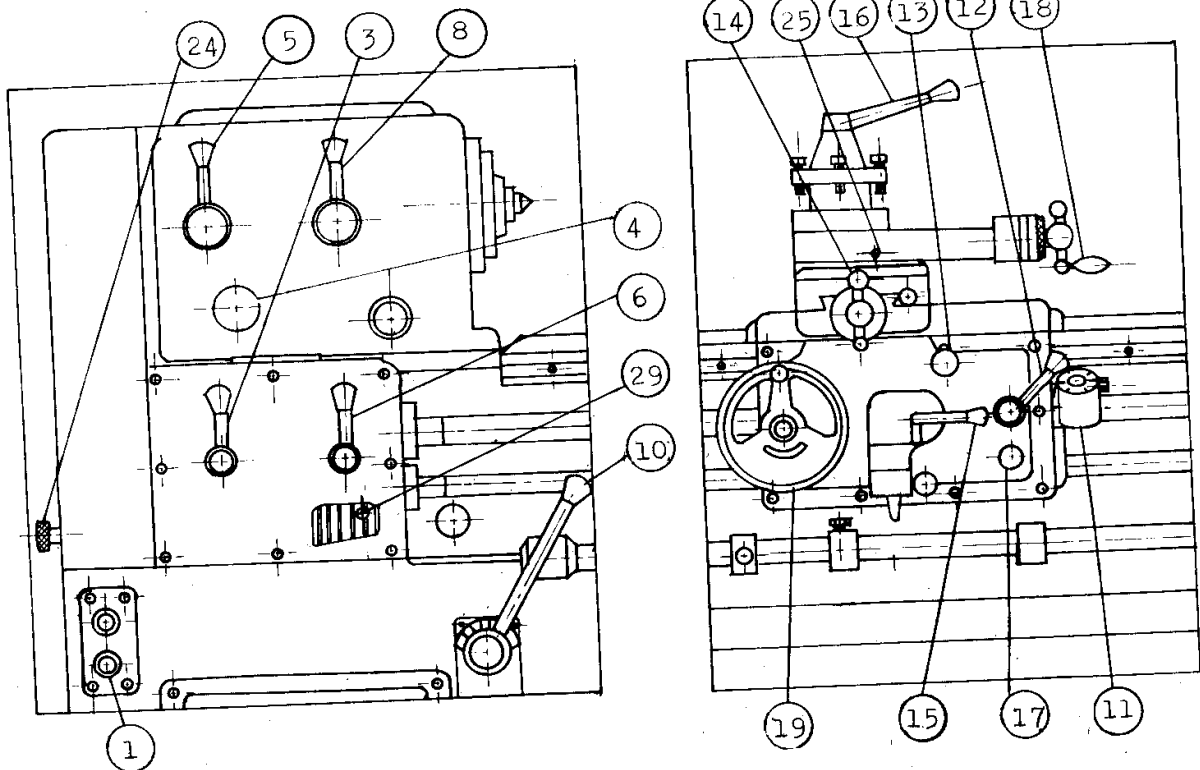

## Operation of thread cutting

1. Assemble the change gears according to the index plate.
2. Place the feed change lever (3), (29) on the desired position according to the index plate.
3. Place the feed thread change lever (6) to the "THREAD" side.
4. Mesh the chasing gear (11) with the leadscrew.
5. Turn the forward and reverse knob (4) to the left.
6. Place the starting lever (10) to the left.
7. Push down the half nut lever (12).

(Note) The feed change knob (13) and the half nut lever (12) are interlocked to prevent simultaneous engagement. The chasing dial (11) permits the operator to take a thread cutting, however, you can not use it in case of metric thread cutting with inch size leadscrew.

## Automatic longitudinal feed stop bar

1. Fix the tool bit on the tool post.
2. Move the tool at the required position by the handwheel (19).
3. Place the lever (15) to starting position.
4. Contact with the bolt (30) to the plate (35).
5. Move the block (31) until the lever (15) will drop.
6. After that, tighten the clamp bolt (32).

Make sure that the plate (35) will not contact with the block (31) when not in use.

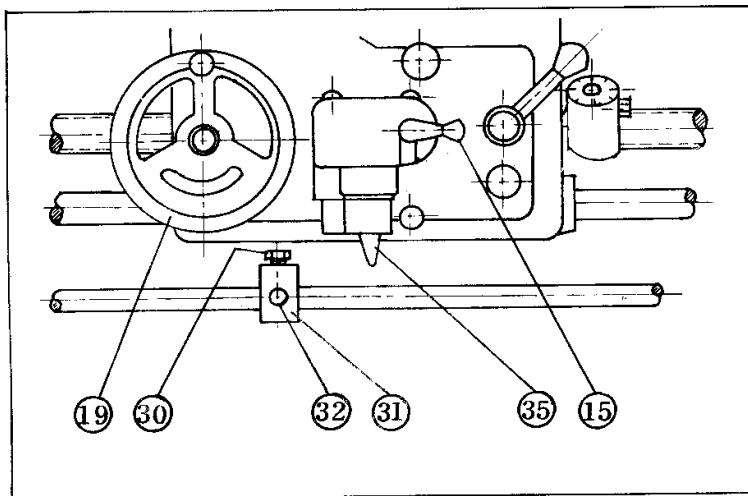

## Tailstock

When moving the tailstock, loosen the tailstock body locking lever (22) and after moving it, lock it tightly.

Movement of the tailstock spindle is operated by tailstock spindle feed handle (23). One turn clockwise of the handle moves the spindle 4mm. After feeding the spindle, lock the lever again.

Tailstock center taper is MT No.3 and 120mm long.

(See fig 5)

## Mounting of chuck and face plate

Before mounting them, clean their taper parts.

Mount the back plate for the chuck tightly and then mount the chuck with bolts.

When you tighten bolts, never tighten only one bolt tightly.

Chuck and face plate are pre-balanced not to run-off at high speed rotation.

## THREAD CHASING DIAL

The thread chasing dial is mounted on the upper right side of apron.

IN CASE OF 1/2" LEADSCREW ( 6 TPI)

The structure of chasing dial for cutting threads is as following diagram.

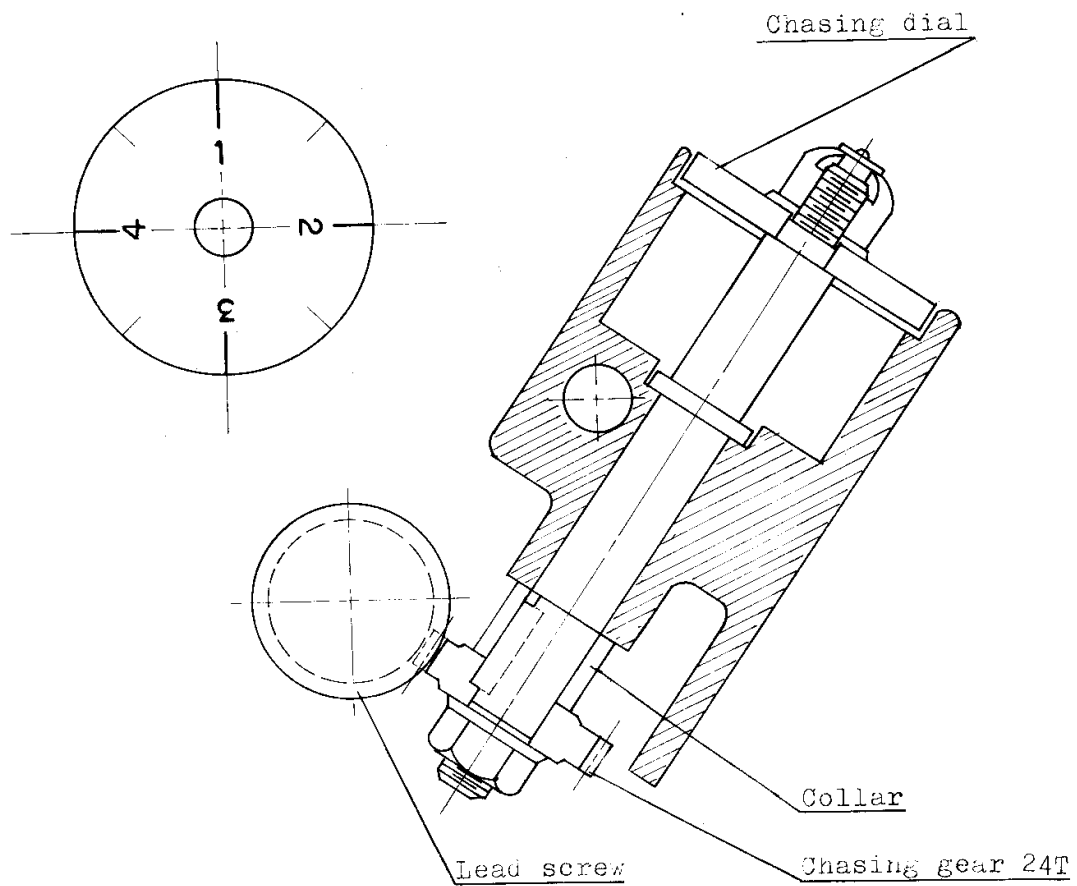

## ADJUSTMENT

Parts are adjusted before we ship this machine, so you have no need of readjustment except in case of trouble. But if it needs adjustment as follows.

### Leveling of the bed slide ways

The accuracy depends on leveling of the bed slide ways, so take care installing the machine. Also after installing the machine, examine the level of the bed slide ways regularly. Don't use your lathe in bad accuracy because it will occur to the twist of the bed.

### Adjustment of the headstock

When adjusting the level of the spindle center, take off the rear cover, properly loosen the headstock clamping bolts and adjust the headstock adjusting bolts as the following figure shows. It is rarely necessary to do this kind of adjustment.

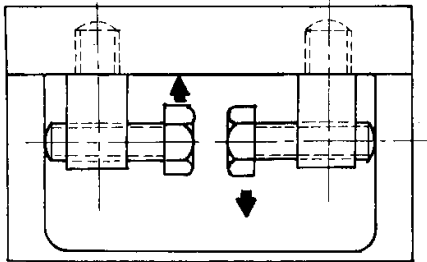

### Adjustment of the spindle bearing

The spindle is supported by a two point mounting system of the taper roller bearing #30211 and #32214. Both of them are properly adjusted before we ship this machine, so you have no need of readjustment except in case of trouble. However if either looseness or slackning should happen to them due to an unexpected condition or the wear of the machine, remove the rear cover of the headstock and adjust the ring nut. Be careful not to lock the nut too tight, otherwise the spindle will be overheated or damaged in high speed revolution due to overcharge of the preload.

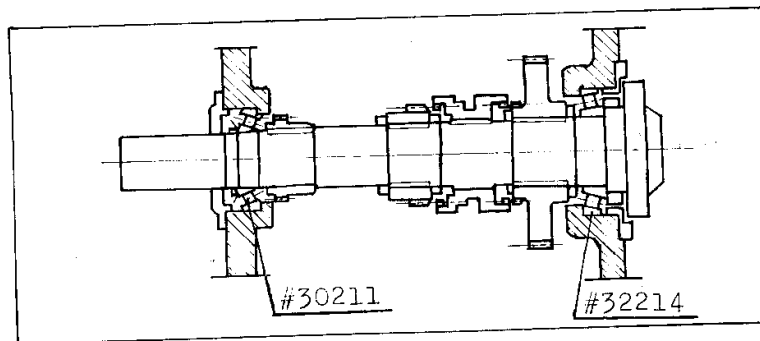

### Adjustment of the apron teeth clutch

When adjusting the apron teeth clutch, remove the cover of the feed on lever (15) and clamp the nut little by little.

### Adjustment of the gibs

The cross slide and the tool rest contain the taper gibs which were adjusted but if it has slackened after many years of use, adjusting bolts must be tightened.

### Adjustment of the female screw of the cross slide

The cross slide has a device to eliminate backlash of the feed screw and the female screw. If the backlash becomes greater, loosen the bolt (A) slightly. Then screw the bolt (B). After eliminating the backlash, the bolt (A) must be tightened.

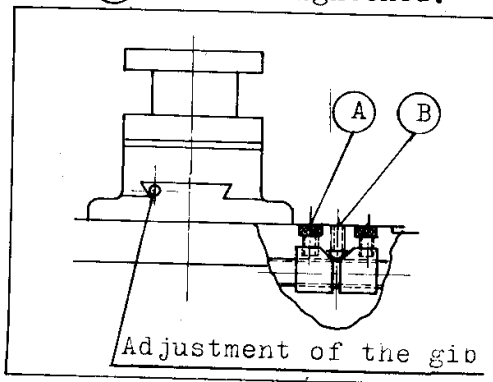

### Centering and adjustment of the tailstock

Centering of the tailstock and simple taper cutting is done by adjusting bolts. But in the case of regular taper turning, a taper attachment must be used. The tailstock is designed to pull up the clamp plate by means of the eccentricity of its axis. In case the locking power is weakened, adjust the nut (A) after loosening the socket screw (B) and then tighten the socket screw (B) again.

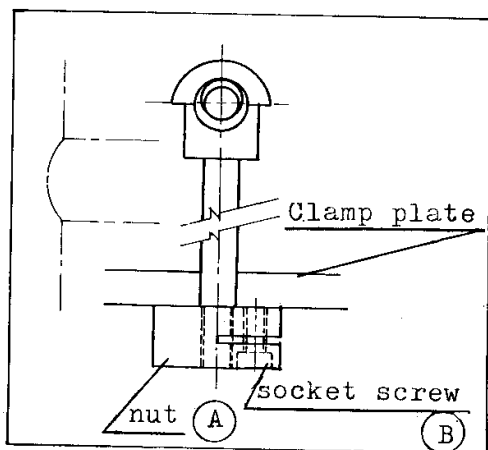

### Adjustment of the brake

Your machine is equipped with foot brake. Brake band is composed of a lining and lining holder. If the lining is worn out, loosen the nut (1) and tighten the bolt (2) to a suitable position. After adjustment, retighten the nut (1).

(Note) Make sure the position of the bolt (3) if it is in touch with the roller of the limit switch. After adjusting them, tighten the nut (4).

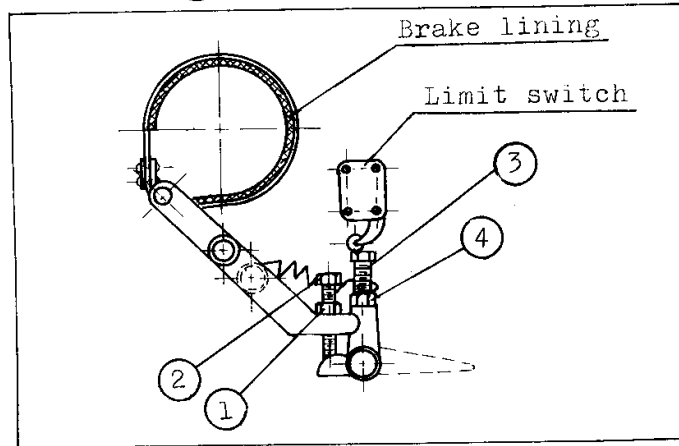

### Adjustment of the microswitch

In case the cams of holding down the microswitch are in bad condition, adjust them after removing the cover as follows.

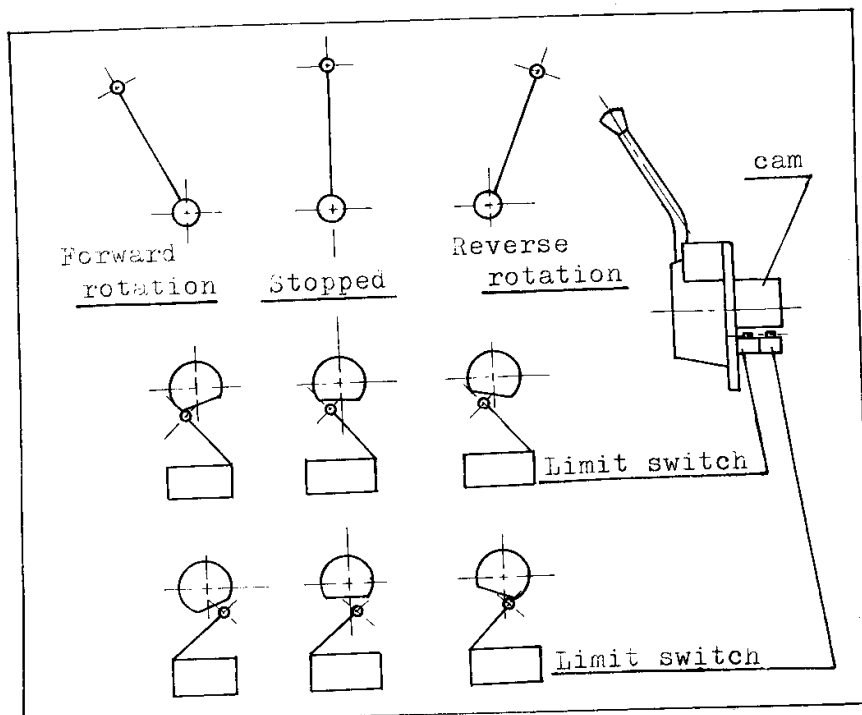



Adjustment of the square turret tool post

1. Remove the top lever holder and washer.
2. Loosen three flat screws.
3. Screw the three set screws equally.
4. Tighten the flat screw.

(Note) Don't screw the set screws too much because the rotation of tool post will become hard.

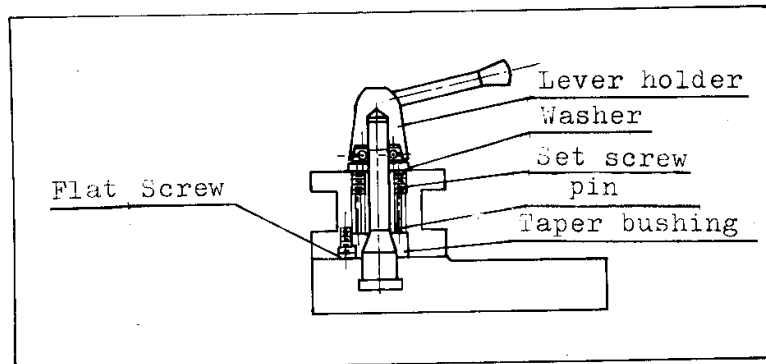

TROUBLE SHOOTING CHART

<u>Trouble</u>	<u>Probable cause</u>	<u>Correction</u>
1. Not start	A. Thermal relay operates for heavy cutting	Push the button for thermal relay
	B. Motor is burnt out	Replace
	C. Bad contact point	Replace
	D. Fuse is out	Replace
2. Motor overheat	A. Over-tight of belt	Adjust the belt tension
	B. Overload	Adjust the load
3. Starting lever is bad	A. Cam for micro switch	Adjust the cam
	B. Micro switch is damaged	Replace
4. Unsuitable spindle rotation	A. Over-tight or over-loose of the belt	Adjust the belt
	B. Motor over-heat	Exchange the coil or replace
5. Headstock over-heat	A. Bearing	Adjust
	B. high speed operation	Low speed operation
	C. Lubricant shortage or dirty lubricant	Replace the lubricant
6. Chatter, gear noise	A. Bad gear mesh	Adjust or replace gear
	B. Bearing	Adjust bearing
	C. Taper gib	Adjust
	D. Chucking is bad	Chuck the workpiece tightly
	F. Bad tools	Replace or adjust
7. Unaccuracy or workpiece	A. Headstock movement	Adjust the headstock
	B. Tailstock	Adjust the tailstock
	C. Chucking is bad	Chuck tightly
	D. Bad tools	Replace or adjust

<u>Trouble</u>	<u>Probable cause</u>	<u>Correction</u>
8. Irregular feed	A. Teeth clutch for feed start lever	Adjust
	B. Feed rod	Adjust
	C. Pinion gear	Adjust the gear or replace
9. Tailstock loose	A. Clamp power weak	Adjust clamp power
10. Brake power weak	A. Brake lining is worn out	Replace the lining
	B. Limit switch is damaged	Replace
	C. Water or oil	Clean
11. Cross slide movement does not coincide with dial movement	A. Backlash of female screw is large	Adjust the female screw

## NOTES IN GENERAL

In addition to the above as to handling and operation of your lathe, the following applies:

1. Avoid strong sun light keep machine off a heater or stove, otherwise it will be strained and affect precision.
2. Don't use impure oil for the machine.
3. Never fail to clean or lubricate the main parts of the machine each day. Please place the carriage close to the tailstock when not use.
4. When work is in the headstock, do not give it a strong blow with a hammer. This will affect spindle accuracy.
5. Be careful not to leave the sliding parts of the carriage and bed with grinding dust or sand. Particularly be most careful not to damage any part of the machine with dropping of tools. Any small mark or crack will affect the movement of the carriage on the ways.
6. In damp weather cover the machine with a vinyl cover or grease to prevent it from water, dripping and rusting.
7. Be sure to turn off the pilot lamp when not in use.